

# Unified Modeling Language 2

## State machines

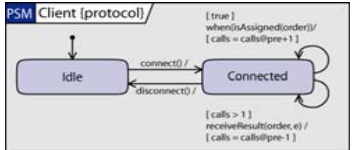
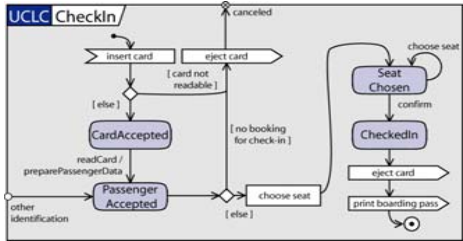
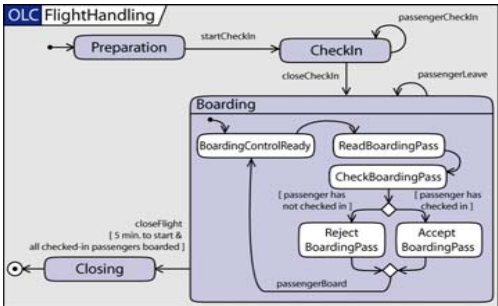
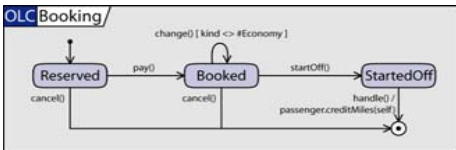

# History and predecessors

---

- 1950's: Finite State Machines
  - Huffmann, Mealy, Moore
  
- 1987: **Harel Statecharts**
  - conditions
  - hierarchical (and/or) states
  - history states
  
- 1990's: Objectcharts
  - adaptation to object orientation
  
- 1994: **ROOM Charts**
  - run-to-completion (RTC) step



# States and transitions

- State machines model behaviour
  - using **states** interconnected ...
  - with **transitions** triggered ...
  - by **event** occurrences.

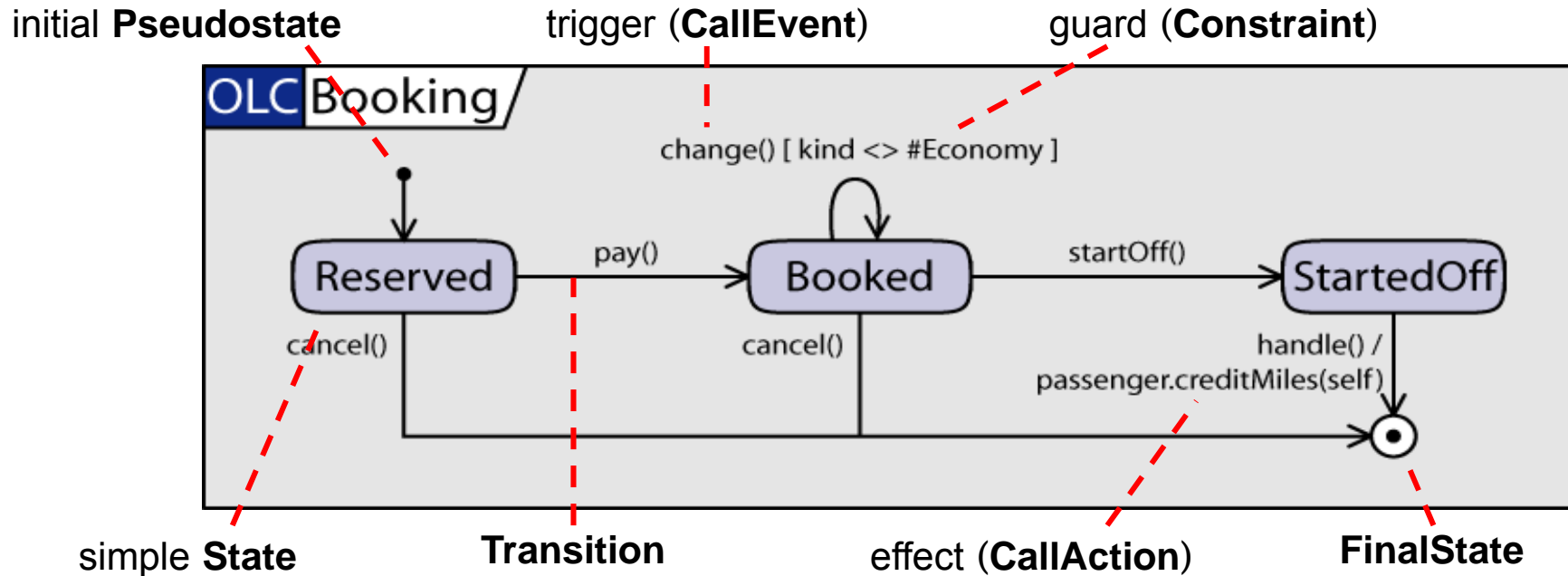
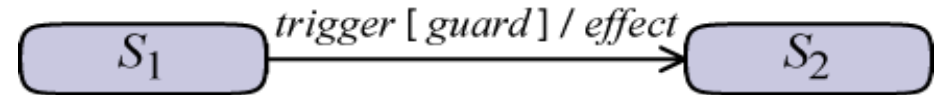

# Relation to class diagrams

- State machines are defined in the context of a BehavioredClassifier.

- **Context** defines which

- events can occur
- features are available

**Operation**  
corresponding **CallEvent**

**CallAction**

called **Operation**

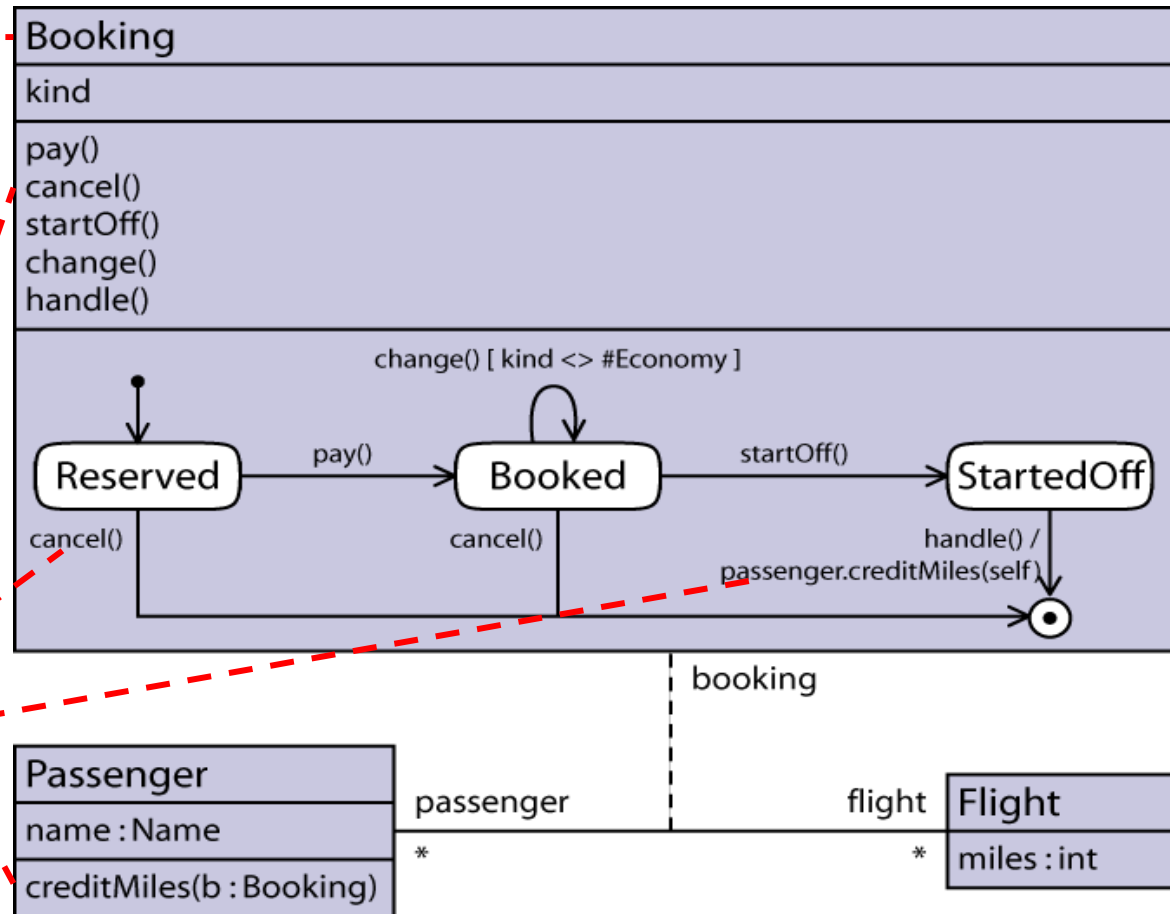

# Triggers and events (1)

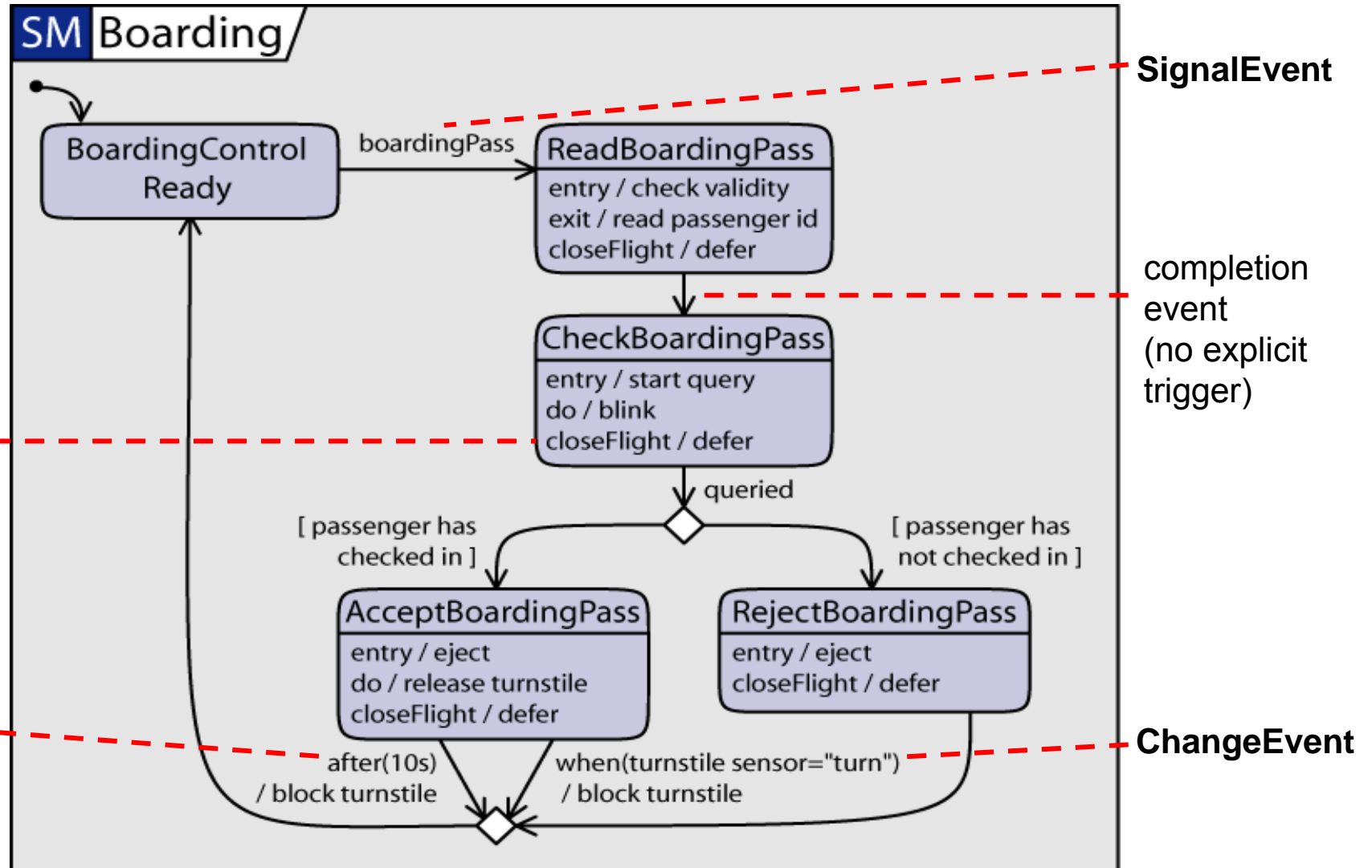



## Triggers and events (2)

---

- **CallEvent**
  - receipt of a (a)synchronous Operation call
  - triggering after Behavior of Operation executed
- **SignalEvent**
  - receipt of an asynchronous Signal instance
  - reaction declared by a Reception for the Signal
- **TimeEvent**
  - absolute reference to a time point (at  $t$ )
  - relative reference to trigger becoming active (after  $t$ )
    - presumably meaning relative to state entry
- **ChangeEvent**
  - raised each time condition becomes true
    - may be raised at some point after condition changes to true
    - could be revoked if condition changes to false



# Triggers and events (3)

- **Completion event**

- raised when all internal activities of a state are finished
  - do activity, subregion
  - no metamodel element for completion events
- dispatched before all other events in the event pool

- **Deferred events**

- events that cannot be handled in a state but should be kept in the event pool
  - reconsidered when state is changed
  - no predefined deferring policy

- **Internal transitions**

- ... are executed without leaving and entering their containing state
  - normally, on transition execution states are left and entered

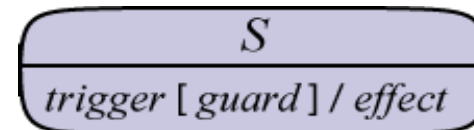



# Behaviours

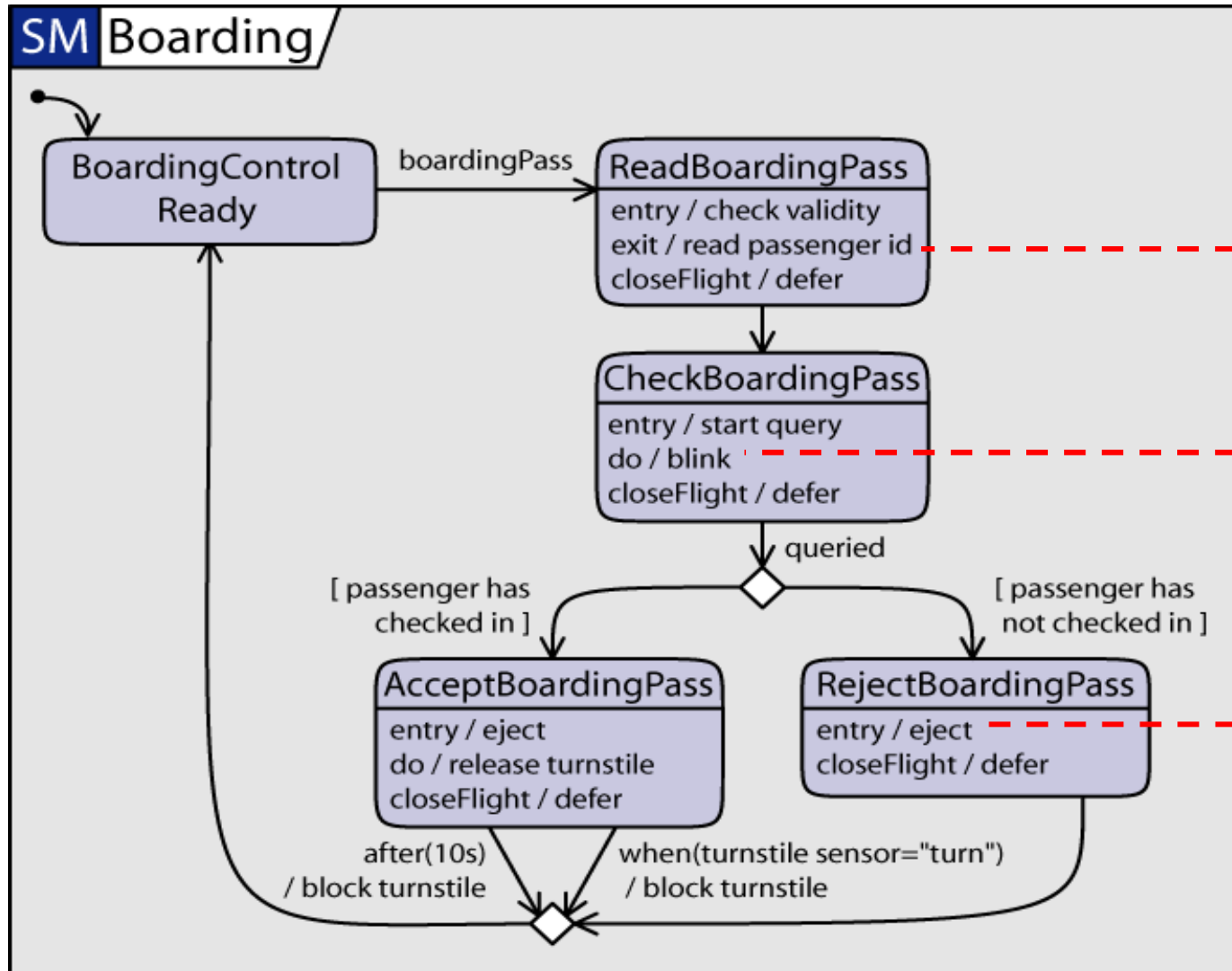

exit **Behavior**  
(on exiting a state)

do activity **Behavior**  
(concurrently while  
in state, may be  
interrupted)

entry **Behavior**  
(on entering a state)

# How state machines communicate

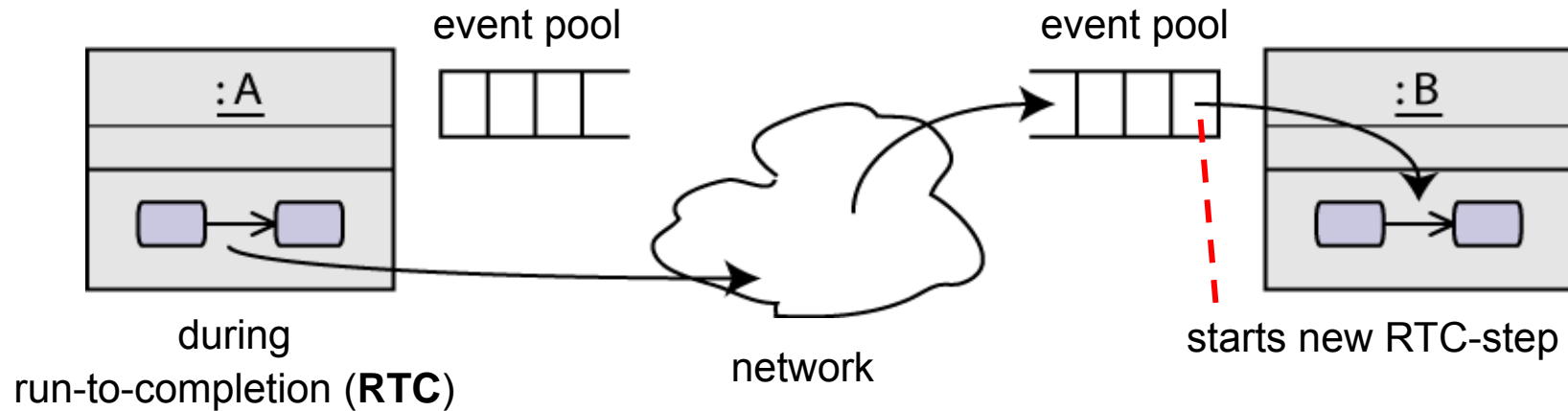

signals: *asynchronous* (no waiting)

calls: *asynchronous* or *synchronous* (waiting for RTC of callee)

No assumptions are made on timing between event occurrence, event dispatching, and event consumption.

Event occurrences for which no trigger exists may be discarded (if they are not deferred).

# Hierarchical states (1)

- Hierarchical states allow to **encapsulate** behaviour and facilitate reuse.
- However, they are rarely used this way.
- UML 2.0 provides concepts supporting this usage.
  - entry and exit points

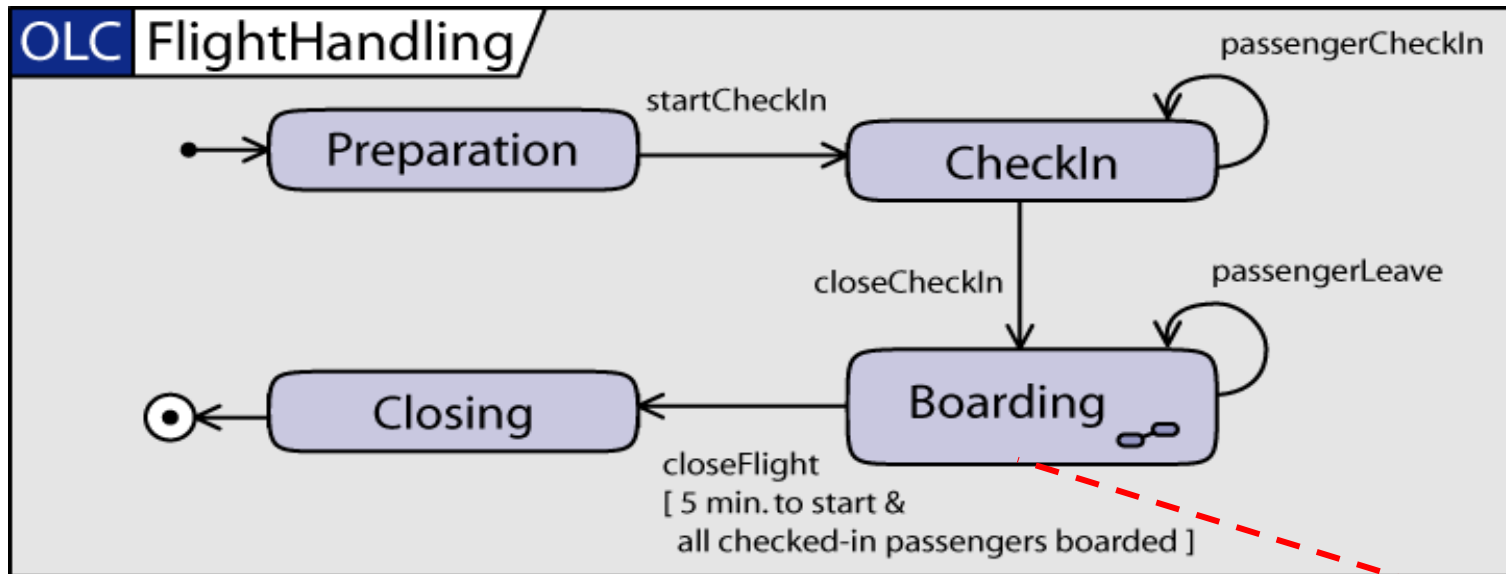

composite **State**

Transition triggering is **prioritized** inside-out, i.e., transitions deeper in the hierarchy are considered first.

# Hierarchical states (2)

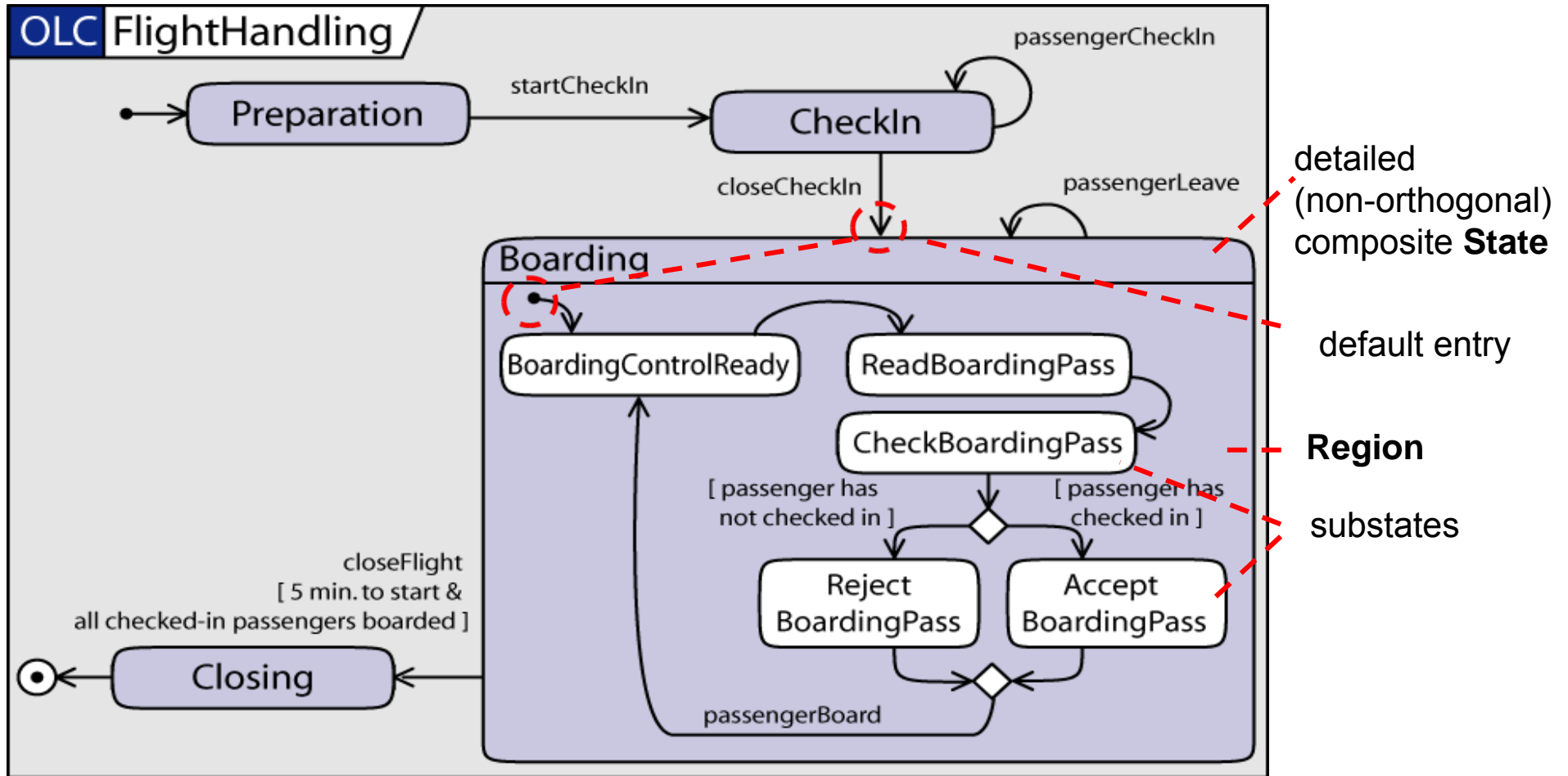

# Orthogonal regions

- **Simple State:** containing no Region
- **Composite State:** containing at least one Region
  - simple composite State: exactly one
  - orthogonal composite State: at least two

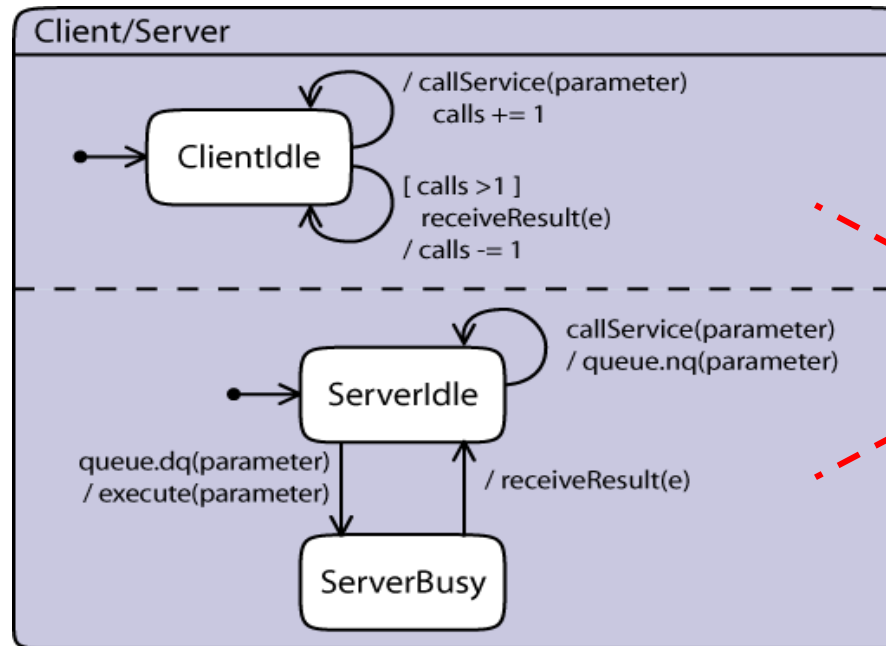

orthogonal **Regions**,  
both active if  
Client/Server active

orthogonal states are “concurrent” as a single event may trigger a transition in each orthogonal region “simultaneously”

# Forks and joins

all Regions must be entered simultaneously

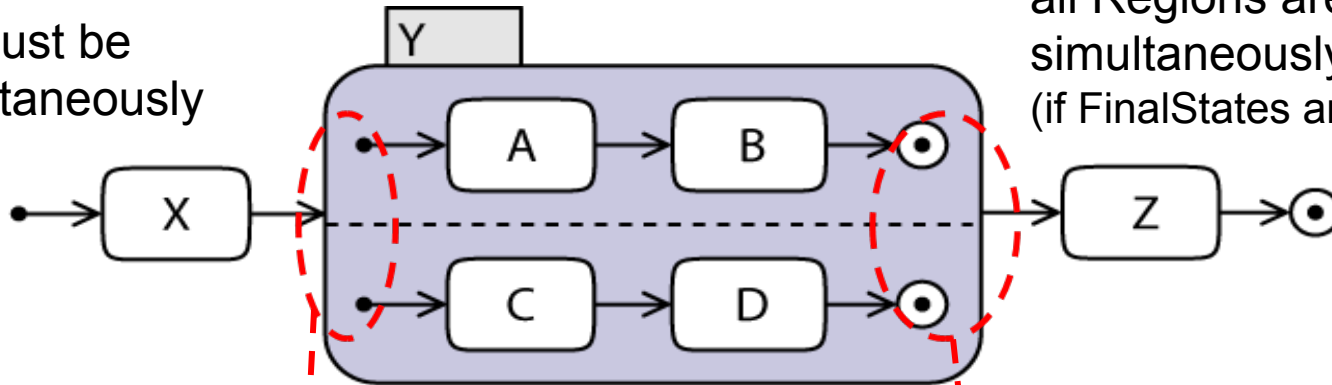

all Regions are left simultaneously  
(if FinalStates are reached)

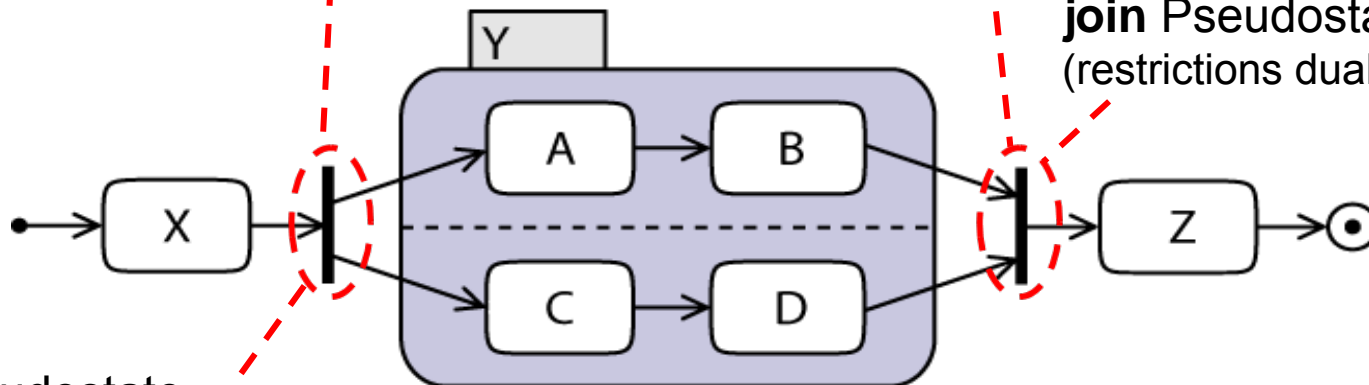

**join** Pseudostate  
(restrictions dual to forks)

**fork** Pseudostate  
(one incoming, at least two outgoing Transitions;  
outgoing Transitions must target States in different Regions of an orthogonal State)